

Voltage SecureData

End-to-end data-centric security for the new data-driven economy



The Challenge in Data Security

The volume of data, the sophistication of ubiquitous computing and the borderless flow of data are outpacing the ability to understand how personal data is being used. In this data-driven economy, 78 percent of consumers think it is hard to trust companies when it comes to the use of their personal data.¹ Why? The number of cyber attacks against enterprises and governments globally, continues to grow in frequency and severity.

The findings in the Ponemon Institute Cyber Crime Study² suggest companies using encryption technologies are more efficient in detecting and containing cyber attacks. As a result, these companies enjoyed an average cost savings of \$883,000 USD annually when compared to companies not deploying encryption technologies. These companies deploying encryption technologies also experienced a substantially higher ROI (at 21 percent) than other technology categories.

Voltage SecureData provides an end-to-end data-centric approach to enterprise data protection. It is the only comprehensive data protection platform that enables you to protect data over its entire lifecycle—from the point at which it's captured, throughout its movement across your extended enterprise, all without exposing live information to high-risk, high-threat environments. That's the essence of data-centric security.

Voltage SecureData includes next generation technologies, Hyper Format-Preserving Encryption (FPE), Hyper Secure Stateless Tokenization (SST), Stateless Key Management, and data masking. Voltage SecureData "de-identifies" data, rendering it useless to attackers, while maintaining its usability, usefulness, and referential integrity for data processes,

1 *Rethinking Personal Data: A New Lens for Strengthening Trust*, World Economic Forum, May, 2014.
 2 *2015 Cost of Cyber Crime Study: Global*. Ponemon Institute, October 2015.

Highlights of Voltage SecureData Next Generation Capabilities

- Hyper FPE, a next generation high performance format-preserving encryption for virtually unlimited data types
- FIPS 140-2 validated solution, sensitive data is protected with NIST-Standard FF1 AES encryption, pioneered by Hewlett Packard Enterprise
- Designed for compute intensive demands and the explosion of data and formats that need protection across a broad array of use cases
- Flexible range of interfaces including REST, simple APIs, and native for easier integration with broad range of databases, applications, and platforms
- Hyper SST—Next generation high performance tokenization
- More flexible encryption for global markets with Unicode language support
- Supports the encryption and pseudonymization guidance in the new General Data Protection Regulation (GDPR) legislation for European Union



applications, and services. Voltage SecureData neutralizes data breaches by making your protected data absolutely worthless to an attacker, whether it is in production, analytic systems, or test/development systems, such as training and quality assurance.

A Unique Approach to End-to-End Encryption

Voltage SecureData is a unique, proven data-centric approach to protection—where the access policy travels with the data itself—by permitting data encryption and tokenization without changes to data format or integrity, and eliminating the cost and complexity of issuing and managing certificates and symmetric keys. As a result, leading companies in financial services, insurance, retail, healthcare, energy, transportation, telecom and other industries have achieved end-to-end data protection across the extended enterprise with success in as little as 60–90 days, because of the minimum, in most cases zero, impact to applications and database schemas.

Short Time to Success with Data Security

Most applications can operate using protected data without change. For those applications where sensitive data is first captured or live data is needed for controlled business purposes, Voltage SecureData can easily be used with virtually any system, ranging from decades-old custom applications to the latest enterprise programs. Powerful, centrally managed, policy-controlled APIs, such as a REST API and command line tools, enable encryption and tokenization to occur on the widest variety of platforms, including Vertica, NonStop, Teradata, IBM mainframe, Linux and other open systems. APIs enable broad deployment into portfolios including ETL, cloud, databases and applications, network appliances, and API brokers such as F5 load balancing, and Hadoop with native on-node cluster-wide data masking, encryption and decryption. SIEM/SIM systems

can take event data from Voltage SecureData or data governance reporting, activity monitoring, and audit.

Voltage SecureData protects information in compliance with PCI DSS, HIPAA, GLBA, state and national data privacy regulation as well as the European Commission's General Data Protection Regulation (GDPR), applicable in all EU member states. Voltage SecureData is also compatible with the more stringent PCI DSS 3.2's new requirements on transport encryption, enabling accelerated compliance ahead of deadlines as recommended by the PCI council. Voltage SecureData enables organizations to quickly pass audit and additionally implement full end-to-end data protection to reduce risk impact of data breaches, all without the IT organization having to completely redefine the entire infrastructure and IT processes or policies. On average, Voltage SecureData requires less than 0.1 full-time employee (FTE) per data center for ongoing management.

Key Benefits

Reduce audit scope, costs, system impact, and resources. Eliminate sensitive data from production and test systems and enable end-to-end data protection. Helps enable compliance to data privacy regulations.

Avoid brand-damaging, costly breaches. Move beyond compliance to easily weave data protection across systems, devices, and platforms.

Industry Standard Format-Preserving Technologies—Securedata with Hyper FPE

Micro Focus Data Security has contributed technology and core specifications for the new *National Institute of Standards and Technology's (NIST) AES FF1 Format-Preserving Encryption (FPE) mode standard*: www.nist.gov/news-events/news/2016/03/new-nist-security-standard-can-protect-credit-cards-health-information

The NIST standard provides an approved and proven data-centric encryption method for government agencies, and has been involved as a developer through open cooperation with NIST from initial proposals of Format-Preserving Encryption technologies with formal security proofs to independent peer review of the NIST AES modes. The NIST standard is critical in setting the bar to ensure organizations are maintaining regulatory and audit compliance, as well as using proven methods to protect against a data breach.

Voltage SecureData is FIPS 140-2 validated, leveraging the NIST FF1 AES encryption standard, providing all the benefits of data-centric security delivered by Hyper FPE—the most flexible and powerful FPE available—with the ability to encrypt virtually unlimited data types.

The work Micro Focus Data Security is doing with NIST, ANSI, IEEE, IETF, and independent security assessment specialists, stands unique in the market. Standards bodies where Voltage SecureData protection technology breakthroughs are published include: NIST, ANSI, IEEE, and IETF.



Hyper FPE: Encryption and Masking—How We Do It

Traditional encryption approaches, such as AES CBC, have enormous impact on data structures, schemas and applications as shown in Figure 1 on the following page. Hyper FPE is NIST-standard using FF1 mode of the Advanced Encryption Standard (AES) algorithm, which

encrypts sensitive data while preserving its original format without sacrificing encryption strength. Structured data, such as Social Security number, Tax ID number, credit card, account, date of birth, salary fields, or email addresses can be encrypted in place.

Traditional encryption methods significantly alter the original format of data. For example, a 16-digit credit card number encrypted with AES produces a long alphanumeric string. As a result, database schema changes are required to facilitate this incompatible format. Hyper FPE maintains the format of the data being encrypted so no database schema changes and minimal application changes are required—in many cases only the trusted applications that need to see the clear data need a single line of code. Tools for bulk encryption facilitate rapid de-identification of large amounts of sensitive data in files and databases. Typically, whole systems can be rapidly protected in just days at a significantly reduced cost. In fact, Hyper FPE allows accelerated encryption performance aligning to the high volume needs of next generation Big Data, cloud and Internet of Things, and supports virtually unlimited data types.

Hyper FPE de-identifies production data and creates structurally valid test data so developers or users can perform QA or conduct data analysis—all without exposing sensitive data. The Voltage SecureData management console enables easy control of policy and provides audit capabilities across the data life cycle—even across thousands of systems protected by Voltage SecureData. Hyper FPE also provides the option to integrate access policy information in the cipher text, providing true data-centric protection where the data policy travels with the data itself.

Stateless Key Management: Transparent, Dynamic

Stateless Key Management securely derives keys on-the-fly as required by an application,



Tax ID
934-72-2356



First name: Gunther
Last name: Robertson
SSN: 934-72-2356
DOB: 08-07-1966

FPE AES-FF1 mode	253-67-2356	First name: Uywjiqo Last name: Muwruwwbp SSN: 253-67-2356 DOB: 08-07-1966
Regular AES-CBC mode	8juYE%Uks&dDFa2345^WFLERG	lja&3k24kQotugDF2390^32 0OWioNu2(*872weW Oiuqriuweuwr%oUOW1@

Figure 1. Format-Preserving Encryption (FPE) versus Regular AES Encryption

once that application and its users have been properly authenticated and authorized against a centrally managed policy. Advanced policy controlled caching maximizes performance. Stateless Key Management reduces IT costs and eases the administrative burden by:

- Eliminating the need for a key database, as well as the corresponding hardware, software, and IT processes required to protect the database continuously or the need to replicate or backup keys from site to site.
- Easily recovering archived data because keys can always be recovered.
- Automating supervisory or legal e-discovery requirements through simple application APIs, both native and via Web services.
- Maximizing the re-use of access policy infrastructure by integrating easily with identity and access management frameworks and dynamically enforcing data-level access to data fields or partial fields, by policy, as roles change.

Unicode Latin 1—Hyper FPE Unicode Latin 1 provides format and character set preserving encryption for global enterprises using data in languages such as German, Spanish, French and more.

GDPR—New national data protection law—European Commission is modernizing data protection legislation by replacing the EU Data

Protection Directive 95/46 EC with the GDPR, which will be directly applicable in all European Union (EU) member states. GDPR pushes the EU into a new era of data privacy, compliance and enforcement in 2018.

Any enterprise handling EU citizens' data needs to revisit the meaning of personal data due to GDPR's expanded definition of personal data. New expanded data includes name, location data, online id, genetic factors, etc. When an enterprise collects sensitive data, personally identifiable information (PII), payment card industry (PCI), or protected health information (PHI), it must secure and protect that data. Enterprises face significant financial penalties for non-compliance.

Voltage SecureData de-identification and privacy protection of sensitive data, production and non-production, including PII, PHI, and PCI, throughout the enterprise, provides end-to-end data-centric security. Hyper FPE delivers strong and flexible encryption to protect EU citizen's personal data and to follow pseudonymization guidance in the new GDPR.

Protecting high value data in government—Voltage SecureData has achieved the industry's first Federal Information Processing Standard (FIPS) 140-2 validation of Format-Preserving Encryption (FPE). Now, government agencies and private contractors serving government customers, can leverage the same powerful

and proven technology that has transformed cybersecurity in the private sector.

Professional Services—Available to help clients' scope projects, combat advanced threats, reduce compliance burden, and quickly solve difficult data privacy challenges.

Hyper SST (Secure Stateless Tokenization)

Hyper Secure Stateless Tokenization (SST) is an advanced, patented, data security solution that provides enterprises, merchants, and payment processors with a new approach to help assure protection for payment card data. Hyper SST is offered as part of the Voltage SecureData platform that unites market-leading encryption, tokenization, data masking, and key management to protect sensitive corporate information in a single comprehensive solution.

Hyper SST is "stateless" because it eliminates the token database, which is central to other tokenization solutions, and removes the need for storage of cardholder or other sensitive data. Hyper SST uses a set of static, pre-generated tables containing random numbers created using a FIPS random number generator. These static tables reside on virtual "appliances"—commodity servers—and are used to consistently produce a unique, random token for each clear text Primary Account Number (PAN) input, resulting in a token that has no relationship to the original PAN. No token database is required with Hyper SST, thus improving the speed, scalability, security and manageability of the tokenization process. In fact, Hyper SST effectively surpasses the existing "high-octane" SST tokenization performance.

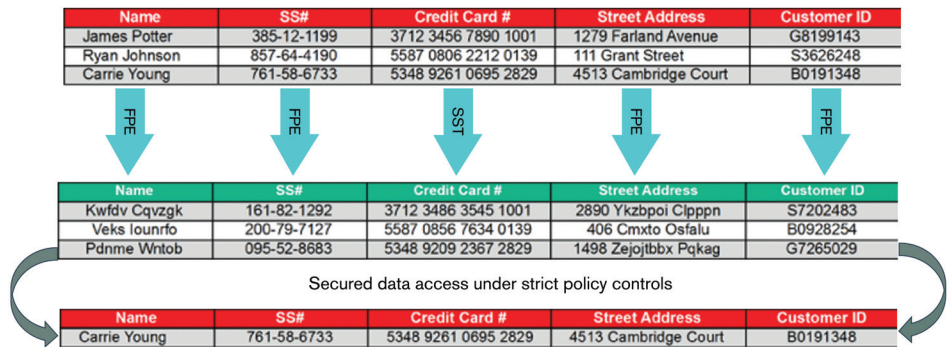

Figure 2. Data Protection with Hyper FPE and Hyper SST

Voltage SecureData Architecture

Voltage SecureData solutions share a common infrastructure, including the same centralized servers and administration tools. This enables Voltage SecureData customers to choose an

appropriate combination of techniques to address their use cases, across diverse environments, while avoiding the costs and complexities of deploying and managing multiple products.

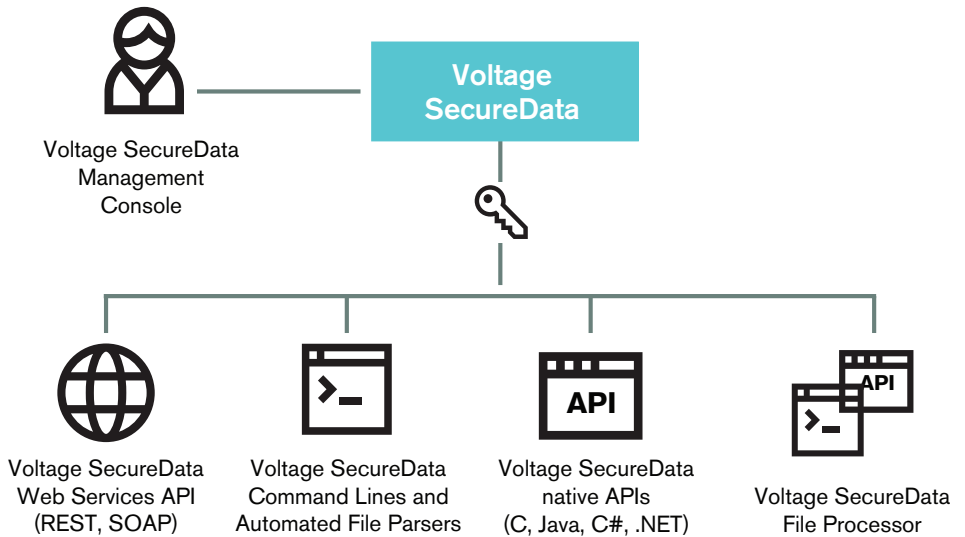
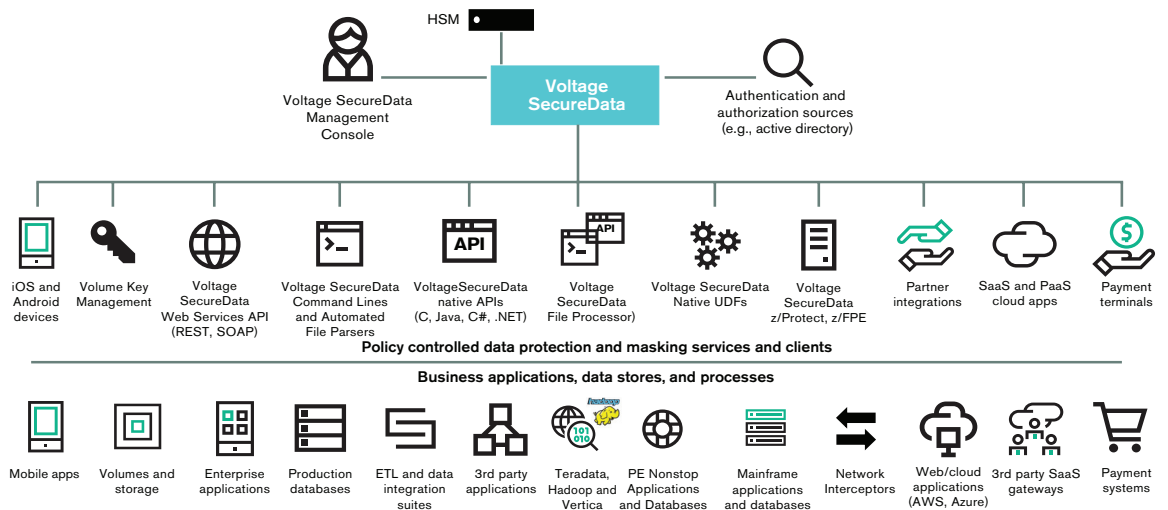

Figure 3. Voltage SecureData Architecture with virtual servers and administration tools

Voltage SecureData Platform Modules	Description
Voltage SecureData Management Console	Enforces data access and key management policies, and eliminates the need to configure each application, because flexible policies are centrally defined and reach all affected applications. Manages data format policies, business rules enforcement over data access, integration with enterprise authorization and authentication systems and connectivity to enterprise audit and security event monitoring systems. It also manages data security policies such as the choice of Hyper FPE, file encryption, and data masking.
Key Management Server	High-scale, on-demand, stateless key management eliminates the need for traditional complex storage-based key management, because keys are dynamically derived; seamlessly integrates with existing Identity Management and Authorization Systems and Key Management using FIPS 140-2 Hardware Security Modules.
Voltage SecureData Web Services Server	Centralized Web services encryption and tokenization option for Service Oriented Architecture environments, enterprise applications and middleware. Supports SOAP and REST API Web services, and Unicode Latin 1 for native languages.
Voltage SecureData Simple API	Maximizes efficiency on a broad range of application servers through native encryption on HP-UX, SAP HANA, NonStop, Microsoft Azure, Amazon Web Services (AWS), Solaris, Stratus VOS, Linux (Red Hat, SUSE, CentOS), AIX, and Windows. Additional APIs are available for embedded platforms such as payment terminal devices. Supports hardware accelerated encryption processes where available, e.g., Intel AES-NI.
Voltage SecureData Command Lines	Scriptable tools easily integrate bulk encryption, tokenization, and file encryption into existing batch operations and applications.
Voltage SecureData File Processor	Aggregates support for both tokenization and encryption of sensitive data elements. It provides a unique value to the customer as a single client converging both Web services and native API interfaces. The converged clients expand the support for new file types by decoupling input file processing from the underlying encryption and tokenization operations. Delivers high performance data de-identification, with parallel multi-threaded processing of sensitive data elements simultaneously protecting data fields across columns.
Voltage SecureData Mobile	Includes simple data security libraries to easily incorporate into native mobile applications. This enables the mobile application to secure captured data end-to-end to the trusted host using a one-time cryptographic key. Supports iOS and Android.
Voltage SecureData also supports mainframe, Big Data, and payment security ecosystems	<ul style="list-style-type: none"> ■ Voltage SecureData z/Protect: Maximizes CPU performance on mainframe systems through native z/OS support for encryption and tokenization. ■ Voltage SecureData z/FPE: Mainframe data processing tool to fast track integration into complex record management systems such as VSAM, QSAM, DB2, and custom formats. De-identify sensitive data for production and test use. ■ Voltage SecureData for Hadoop Developer Templates: Enable customers to integrate FPE and SST technologies into their Hadoop instances. Templates come with pre-built integrations for NiFi, Sqoop, MapReduce and Hive, and can be quickly expanded to integrate into other technologies in the Hadoop stack such as Flume. ■ Voltage SecureStorage: Data-at-rest encryption for Linux with Stateless Key Management. ■ Voltage SecureData Web and Optional Add-ons: Secures data end-to-end from browser applications and forms to secure back-end applications, extending end-to-end security beyond transport encryption such as SSL and TLS. ■ Voltage SecureData Terminal SDK and Host SDK: Provide market-leading P2PE payments security.

Figure 4. Voltage SecureData Architecture addresses use cases for enterprises across diverse environments.



Learn More At
<https://software.microfocus.com/products>

“We needed fast deployment in an environment that is reluctant to change, but we were able to move through very quickly. We were able to get PCI compliant, which is a very big win for us, and improve our s security and the additional controls around the data as it’s being moved, and we have very few support calls.”

TIM MASSEY

Director of Enterprise Information Security
AAA—The Auto Club Group

www.microfocus.com



Micro Focus

UK Headquarters

United Kingdom
+44 (0) 1635 565200

U.S. Headquarters

Rockville, Maryland
301 838 5000
877 772 4450

Additional contact information and office locations:

www.microfocus.com